

TYPICAL CROSS SECTION "B-B"

- NOTE:
1. THE PRIMARY OBJECTIVE IS TO PREVENT WATER FROM DRAINING ONTO THE ROAD SURFACE THERE ARE NUMEROUS COMBINATIONS WITH ELEVATIONS THAT PRODUCE THE IDEAL DRIVE.
 2. GRADES FOR MOWING AND SNOW PLOWING SHOULD ALWAYS BE CONSIDERED.
 3. A 90° ELBOW RISER W/YARD GRATE IS OPTIONAL.
 4. DRIVES ON COUNTY ARTERIALS REQUIRE CONCRETE OR ASPHALT PAVEMENT FROM EDGE OF ROAD TO EDGE OF RIGHT-OF-WAY.

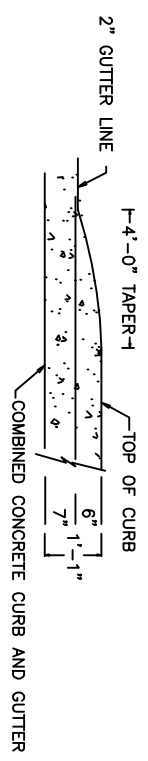

CURB TAPER DETAIL "A-A"

ELEVATION

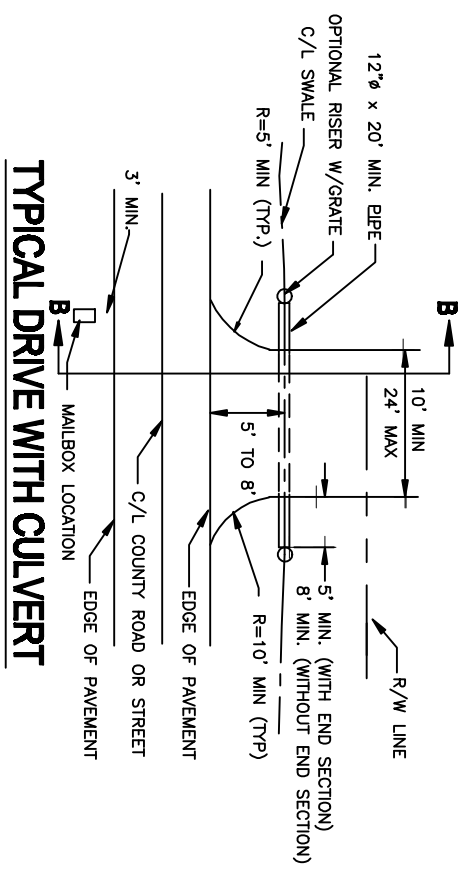

TYPICAL DRIVE WITH CULVERT

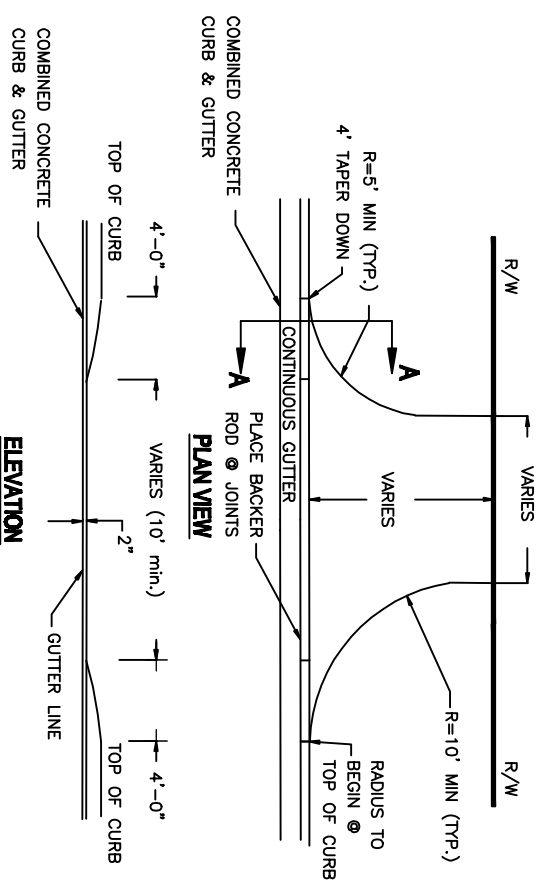

TYPICAL CURB CUT "A-A"

ELEVATION

RESIDENTIAL PRIVATE DRIVE

FIG.5

